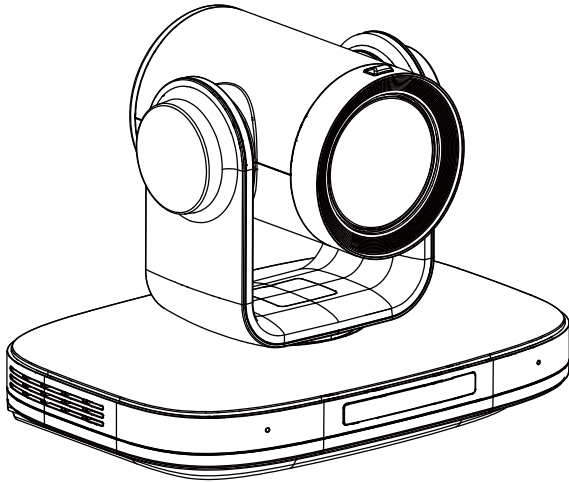

PeopleLink 4K PTZ Elite 12X CameraProduct Manual | Edition V 1.0 | Release 012025 | PPU-PVC-FHD-4k-12X

**User Manual****(English Version)**

Please read this Manual before setting up 4K PTZ Elite 12X camera and stick to its requirements strictly for Safety reason. Suggest you save this manual for further inquiries reference.

2017 PeopleLink Unified Communications Pvt. Ltd. All rights reserved.

PeopleLink Unified Communications Pvt. Ltd.

Q3-A3, 10th Floor, Cyber Towers, Hitech City

Madhapur, Hyderabad – 500081

India

No part of this document may be reproduced or transmitted in any form or by any means, electronic or mechanical, for any purpose, without the express written permission of PeopleLink. Under the law, reproducing includes translating into another language or format. As between the parties, PeopleLink, retains title to and ownership of all proprietary rights with respect to the software contained within its products.

Therefore, you must treat the software like any other copyrighted material (e.g., a book or sound recording). Every effort has been made to ensure that the information in this manual is accurate.

PeopleLink, is not responsible for printing or clerical errors. Information in this document is subject to change without notice.

Catalogue

1	Note.....	1
2	Packing List.....	1
3	Quick Start.....	1
4	About Product.....	2
4.1	Features.....	2
4.2	Product Specification.....	2
4.3	Interfaces and Buttons.....	4
4.4	Dimension.....	4
4.5	Remote Control.....	5
4.6	RS232 Interface.....	6
4.7	VISCA Network.....	6
4.8	Serial Communication Control.....	7
5	GUI Settings.....	7
5.1	MENU.....	7
5.2	EXPOSURE.....	7
5.3	COLOR.....	8
5.4	IMAGE.....	8
5.5	P/T/Z.....	9
5.6	NOISE REDUCTION.....	9
5.7	SETUP.....	9
5.8	COMMUNICATION SETUP.....	9
5.9	RESTORE DEFAULT.....	10
6	Network Function.....	10
6.1	Operating Environment.....	10
6.2	Equipment Installation.....	10
6.3	Internet Connection.....	10
6.4	Camera Controlled by LAN.....	10
6.4.1	Setup IP Address.....	10
6.4.2	Visit/Access Camera.....	11
6.5	Camera Controlled by WAN.....	12
6.5.1	Setup IP Controlled by Dynamic DNS.....	12

6.5.2	Dynamic DNS Visit Camera	12
6.5.3	VLC Stream Media Player Monitor	12
6.6	Camera Parameter Setup	13
6.6.1	Homepage Introduction	13
6.6.2	Video Settings	14
6.6.3	Image Settings	15
6.6.4	Audio Settings	15
6.6.5	System Settings	16
6.6.6	Network Settings	16
6.6.7	NDI® Config	17
6.6.8	Device Information	17
6.7	Download the Upgrade Program	17
7	Maintenance and Troubleshooting	17

1 Note

- **Electric Safety**

Installation and operation must accord with electric safety standard.

- **Use Caution to Transport**

Avoid stress, vibration or soakage in transport, storage and installation.

- **Polarity of Power Supply**

The power supply of this product is +12V, the max electrical current is 2A. Polarity of the power supply plug drawing shows as below.



- **Installation Precautions**

Do not grasp the camera lens when carrying it. Don't touch camera lens by hand. Mechanical damage may be caused by doing so.

Do not use in corrosive liquid, gas or solid

environment to avoid any cover (plastic material) damage. Make sure there is no obstacle within rotation range. Please never power on before installation is completed.

- **Do not Dismantle the Camera**

We are not responsible for any unauthorized modification or dismantling.



Specific frequencies of electromagnetic field may affect the image of the camera!

2 Packing List

Name	Quantity
Camera	1
Remote Control	1
Power Adapter	1
Power Cable	1
RS232 Cable	1
User Manual	1

3 Quick Start

1. Please check connections are correct before starting.

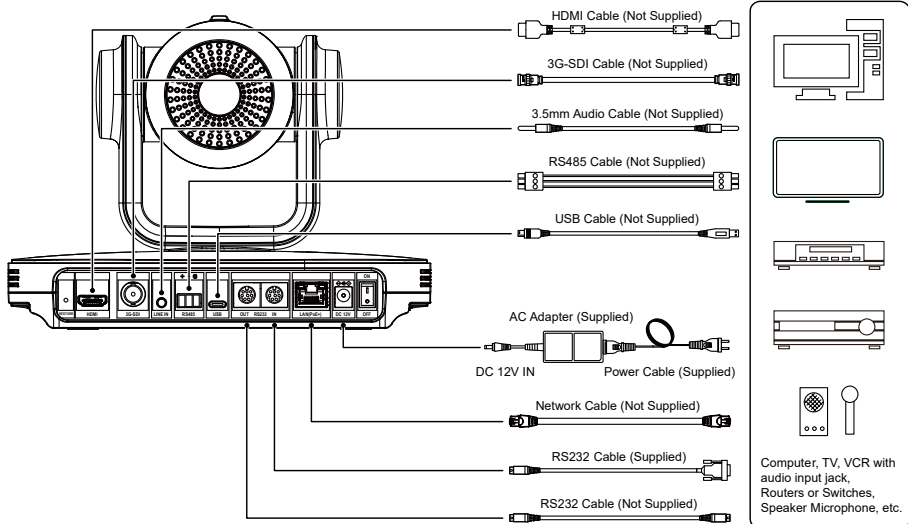

- 2) Connect the power adapter to the power connector on the rear panel of the camera. The power indicator on the front panel of the camera is on.
- 3) After the camera is powered on, it starts to initialize, right up to the limit position, and then both horizontal and vertical go to the middle position, the motor stops running, and the initialization is completed.
(Note: If preset 0 is saved, PTZ will be move to preset 0)

4 About Product

4.1 Features

- **AI Intelligent Tracking**

Built-in AI processor, using deep learning technology to use human shape features, no matter where the face is facing, it can achieve smooth automatic tracking of human shape, which is very suitable for automatic target tracking in lectures, teaching and other scenes.

- **4K Ultra HD**

With a new generation of SONY 1/2.8-inch, maximum 8.40 million pixels high-quality UHD CMOS sensor, 4K (3840x2160) ultra-high resolution images are available. And backward compatible with 1080P, 720P and other resolutions.

- **80° Wide-angle Lens + 12x Optical Zoom**

Exclusively customized high-quality 8 million ultra-high resolution 4K super wide-angle lens, 12x optical zoom, the horizontal field of view up to 80°.

- **HDMI 2.0**

Support HDMI 2.0, it can directly output 4KP60 uncompressed digital video.

- **Low Light**

The application of 3D digital noise reduction algorithm greatly reduces image noise. Even under the condition of ultra-low illumination, it still keep the picture clean and clear, and the

SNR of image is as high as 55dB.

- **Multiple Interfaces**

It supports HDMI 2.0 FHD output and 3G-SDI interface, the effective transmission distance up to 150 meters (1080P30).

- **Remote Control**

Through the RS232 and RS485 serial ports, the camera can be controlled remotely.

- **Intelligent Exposure**

Effectively solve the impact of projection, TV and other equipment on the people who are photographing.

4.2 Product Specification

Camera	
Signal System	HDMI: 4KP25, 4KP30, 4KP50, 4KP60, 4KP59.94, 4KP29.97, 1080P25, 1080P30, 1080P50, 1080P60, 1080P59.94, 1080P29.97, 1080I50, 1080I60, 1080I59.94, 720P50, 720P59.94, 720P60 3G-SDI: 1080P25, 1080P30, 1080P50, 1080P60, 1080P59.94, 1080P29.97, 1080I50, 1080I60, 1080I59.94, 720P50, 720P59.94, 720P60
Sensor	1/2.8 inch, CMOS, Max Effective Pixel: 8.40M
Scanning Mode	Progressive
Lens	12x, f = 3.4mm ~ 41.6mm, F1.8 ~ F3.7
Digital Zoom	16x
Minimum Illumination	0.5 Lux @ (F1.8, AGC ON)
Shutter	1/30s ~ 1/10000s
White Balance	Auto, Indoor, Outdoor, One Push, Manual
Backlight Compensation	Support

Digital Noise Reduction	3D Digital Noise Reduction
Signal Noise Ratio	≥55dB
Horizontal Angle of View	80.8° ~ 7.5°
Vertical Angle of View	49.9° ~ 4.3°
Horizontal Rotation Range	±162.5°
Vertical Rotation Range	-30° ~ +90°
Pan Speed Range	1.8°/s ~ 80.5°/s
Vertical Rotation Speed Range	1.5°/s ~ 49°/s
H & V Flip	Support
Image Freeze	Support
Number of Preset	255
Preset Accuracy	0.1°

USB Features

Operate System	Windows 7/8/10, Mac OS X, Linux, Android
Color System / Compression	YUY2 / MJPEG / H.264 / H.265
Video Format	<ul style="list-style-type: none"> ● YUY2: max to 1080P@30fps ● H.264 AVC/SVC: max to 2160P@30fps ● H.265 SVC: max to 2160P@30fps ● MJPEG: max to 2160P@30fps
USB Audio	Support
USB Video Protocol	UVC 1.1 ~ 1.5
UVC PTZ	Support

Network Features

Video Compression	H.264/H.265/MJPEG
Video Stream	First Stream, Second Stream
First Stream Resolution	3840x2160, 1920x1080, 1280x720, 1024x576, 720x480, 720x408, 640x480, 640x360
Second Stream	720x480, 720x408,

Resolution	640x480, 640x360, 480x320, 320x240
Bit Rate Control	CBR, VBR
Frame Rate	50Hz: 1fps ~ 50fps, 60Hz: 1fps ~ 60fps
Audio Compression	G711A, AAC
Audio Bit Rate	96K, 128K
Protocols	NDI@ HX, TCP/IP, HTTP, RTSP, RTMP(S), ONVIF, DHCP, SRT, Multicast, etc.

Interface / Indicator

LINE IN Interface	1 x LINE IN: 3.5mm Audio Interface
Communication Interface	1 x RS485: 3pin phoenix port, Max Distance: 1200m, Protocol: VISCA / Pelco-D / Pelco-P
	1 x RS232 OUT: 8pin Min DIN, Max Distance: 30m, Protocol: VISCA network use only
	1 x RS232 IN: 8pin Min DIN, Max Distance: 30m, Protocol: VISCA / Pelco-D / Pelco-P
HDMI Interface	1 x HDMI: Version 2.0
LAN(PoE+) Interface	1 x RJ45: 10/100/1000M Adaptive Ethernet Port. It supports PoE+
USB Interface	1 x USB: Type-C
3G-SDI Interface	1 x 3G-SDI: BNC type, 800mVp-p, 75Ω. Along to SMPTE 424M standard
RESTORE Button	1 x RESTORE Button
Power Jack	JEITA type (DC IN 12V)
TALLY Indicator	1 x TALLY Indicator
Power Indicator	1 x Power Indicator
Status Indicator	1 x Status Indicator
Display Screen	1 x Display Screen
Power Switch	1 x Power Switch

General Parameter	
Input Voltage	DC 12V / PoE+(802.3at)
Operating Temperature	0°C ~ 40°C
Storage Temperature	-40°C ~ 60°C
Power Consumption	18W (Max)
Size	223 x 154.8 x 165 (mm)
Net Weight	1.8Kg

4.4 Dimension

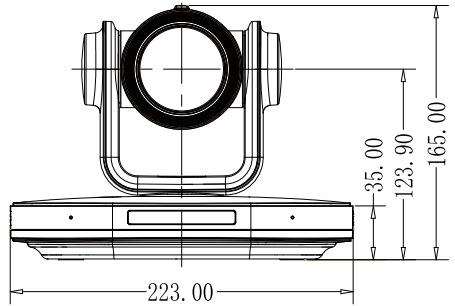

4.3 Interfaces and Buttons

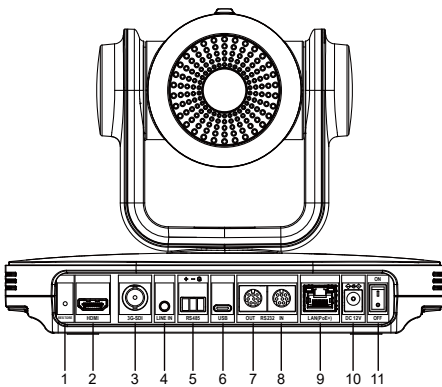

Item	Name
1	RESTORE Button
2	HDMI Interface
3	3G-SDI Interface
4	LINE IN Interface
5	RS485 Interface
6	USB Interface
7	RS232 OUT Interface
8	RS232 IN Interface
9	LAN(PoE+) Interface
10	DC 12V Interface
11	ON/OFF Button

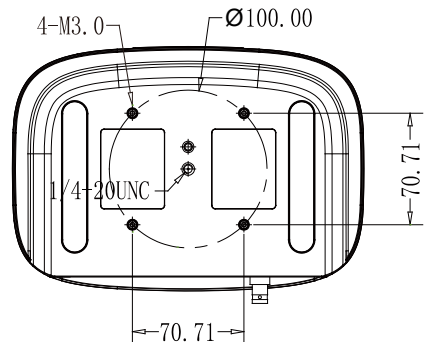
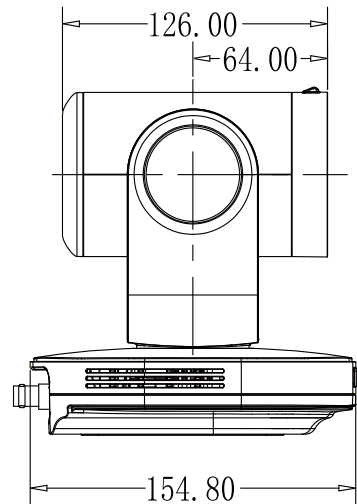

4.5 Remote Control

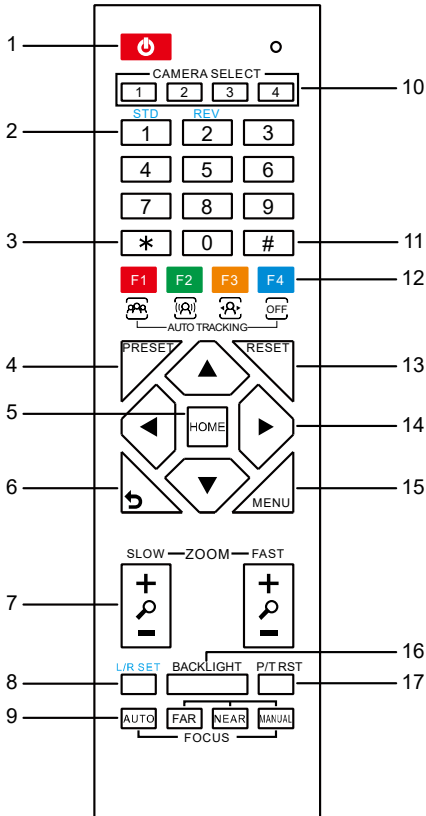

Key Description

1. Standby Key

Press this button to enter standby mode. Press it again to enter normal mode.
Note: Power consumption in standby mode is approximately half of the normal mode

2. Number Key

To set preset or call preset.

3. *Key

Used with other buttons.

4. Preset Key

Set preset: Store a preset position.
[SET PRESET] + Numeric button (0-9):
Setting a corresponding numeric key preset position.

5. HOME Key

Confirm menu, enter the submenu or the PTZ will back to the middle position after pressed it

6. Return Key

Return back the last level menu

7. Zoom Key

Slow Zoom: Zoom In [+] or Zoom Out [-] slowly

Fast Zoom: Zoom In [+] or Zoom Out [-] fast

8. Left/Right Setting Key

Press with 1 button and 2 button setting the direction of the Pan-Tilt.

- Simultaneously press L/R Set + 1[STD]: set the Pan-Tilt turn the same direction as the L/R Set.
- Simultaneously press L/R Set + 2[REV]: set the Pan-Tilt turn the opposite direction as the L/R Set.

9. Focus Key

Used for focus adjustment.

Press [AUTO] adjust the focuses on the center

of the object automatically.

Press [MANUAL] adjust the focus on the center of the object manual.

MANUAL button, and adjust it with [Far] (Focus on far object) and [NEAR] (Focus on near object).

10. Selection Key

Press the button corresponding to the camera you want to operate with the remote controller.

11. #Key

Used with other buttons.

12. Auto Tracking Key

[F1]: Not enabled

[F2]: Not enabled

[F3]: Start AI Intelligent Tracking

[F4]: Stop AI Intelligent Tracking

13. Reset Key

Clear preset: Erase a preset position.

[CLEAR PRESET] + Numeric button (0-9)

Or: [*]+[#]+[CLEAR PRESET]: Erase all the preset individually.

14. PTZ Control Key

Press arrow buttons to perform panning and tilting. Press [HOME] button to face the camera back to front.

15. Menu Key

MENU: enter or exit OSD MENU.

16. Backlight Key

BLC ON/OFF: Press this button to enable the backlight compensation. Press it again to disable the backlight compensation.

NOTE:

- Effective only in auto exposure mode.
- If a light behind the subject, the subject will become dark. In this case, press the backlight ON/OFF button. To cancel this function, press backlight ON/OFF button.

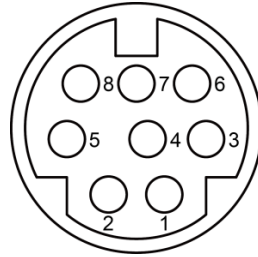

17. PTZ Reset Key

Preset Pan/Tilt self-test.

Image Freezing Function

Manually freeze: Open the freezing function after press the remote control [#]+[*]+[F4], display “Freeze” on the left upper corner character, after five seconds display disappear

automatically. If you want to cancel the freeze, press [#]+[*]+[F4] key and then can return to normal, display “Unfreeze” on the left upper corner, after five seconds display will disappear automatically.

Recalling the Preset image Freeze: By the OSD Menu “Image Freeze” to set recalling the

preset image freeze function. After the function

is opened, the screen will stay in before Recalling the Preset when Recalling the Preset, the screen can be switched to the preset position screen until the camera points to the preset position.

Shortcut Set

- [*]+[#]+[1]: OSD menu default English
- [*]+[#]+[3]: OSD menu default Chinese
- [*]+[#]+[4]: Display current IP address
- [*]+[#]+[6]: Quickly recover the default
- [*]+[#]+[8]: View the camera version
- [*]+[#]+[9]: Quickly set up inversion
- [*]+[#]+[MANUAL]: Restore default IP address

No.	Function
1	DTR
2	DSR
3	TXD
4	GND
5	RXD
6	GND
7	IR OUT
8	NC

The correspondence between the camera and Windows DB-9 pin:

Camera	Windows DB-9
1.DTR	1.CD
2.DSR	2.RXD
3.TXD	3.TXD
4.GND	4.DTR
5.RXD	5.GND
6.GND	6.DSR
7.IR OUT	7.RTS
8.NC	8.CTS
	9.RI

The correspondence between the camera and the Mini DIN pin:

Camera	Mini DIN
1.DTR	1.DTR
2.DSR	2.DSR
3.TXD	3.TXD
4.GND	4.GND
5.RXD	5.RXD
6.GND	6.GND
7.IR OUT	7.NC
8.NC	8.NC

4.6 RS232 Interface

4.7 VISCA Network

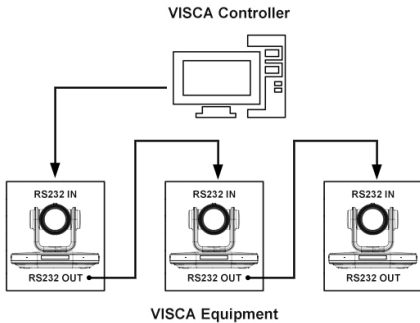

MENU	
Communication Setup	
Restore Default	
[Home]	Enter
[Menu]	Exit

4.8 Serial Communication Control

• RS232 Communication Control

The camera is controlled via RS232. The RS232 serial port parameters are as follows:
 Baud rate: 2400/4800/9600/38400;
 Starting Position: 1 bit
 Data bit: 8 bits
 Stop bit: 1 bit
 Check digit: None

• RS485 Communication Control

Control camera via RS485, half duplex mode:
 Baud rate: 2400/4800/9600/38400;
 Starting position: 1 bit
 Data bit: 8 bits
 Stop bit: 1 bit
 Check digit: None

5 GUI Settings

5.1 MENU

Press [MENU] button to display the main menu on the normal screen, using arrow button to move the cursor to the item to be set. Press the [HOME] button to enter the corresponding sub-menu.

MENU	
▶	Exposure
	Color
	Image
	P/T/Z
	Noise Reduction
	Setup

5.2 EXPOSURE

Move the main menu cursor to [Exposure], and press [HOME] key enter the exposure page, as shown in the following figure.

EXPOSURE		
▶	Mode	Auto
	ExpCompMode	Off
	Backlight	Off
	Gain Limit	9
	Anti-Flicker	50Hz
	Meter	Average
	DRC	0
▲▼	Select Item	
◀▶	Change Value	
	[Menu] Back	

Mode: Auto, Manual, SAE, AAE, Bright.
 ExpCompMode: On, Off (Effective only in Auto mode).
 ExpComp: -7 ~ 7 (Effective only in ExpCompMode item to On).
 Backlight: On, Off (Effective only in Auto mode).
 Bright: 0 ~ 17 (Effective only in Bright mode).
 Gain Limit: 0 ~ 15 (Effective only in Auto, SAE, AAE, Bright mode).
 Anti-Flicker: Off, 50Hz, 60Hz (Effective only in Auto, AAE, Bright mode).
 Meter: Average, Center, Smart, Top.
 Iris: F1.8, F2.0, F2.4, F2.8, F3.4, F4.0, F4.8, F5.6, F6.8, F8.0, F9.6, F11.0, Close (Effective only in Manual, AAE mode).
 Shutter: 1/30, 1/60, 1/90, 1/100, 1/125, 1/180, 1/250, 1/350, 1/500, 1/725, 1/1000, 1/1500, 1/2000, 1/3000, 1/4000, 1/6000, 1/10000 (Effective only in Manual, SAE mode).
 Gain: 0 ~ 7 (Effective only in Manual mode).

DRC: 0 ~ 8.

5.3 COLOR

Move the main menu cursor to [Color], and press [HOME] key enter the color page, as shown in the following figure.

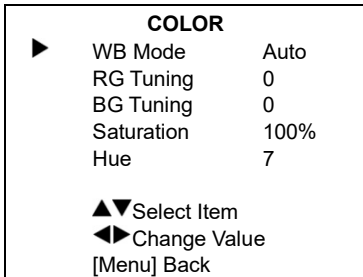

WB-Mode: Auto, Indoor, Outdoor, One Push, Manual.

RG Tuning: -10 ~ +10 (Effective only in Auto mode).

BG Tuning: -10 ~ +10 (Effective only in Auto mode).

Saturation: 60% ~ 200%.

Hue: -10 ~ +10.

RG: 0 ~ 255 (Effective only in Manual mode).

BG: 0 ~ 255 (Effective only in Manual mode).

5.4 IMAGE

Move the main menu cursor to [Image], and press [HOME] key enter the image page, as shown in the following figure.

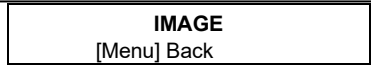
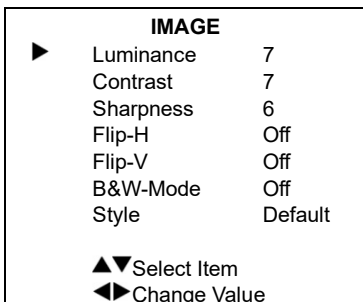

Luminance: 0 ~ 14.

Contrast: 0 ~ 14.

Sharpness: 0 ~ 11.

Flip-H: On, Off.

Flip-V: On, Off.

B&W-Mode: On, Off.

Style: Default, Norm, Bright, PC.

5.5 P/T/Z

Move the main menu cursor to [P/T/Z], and press [HOME] key enter the P/T/Z page, as shown in the following figure.

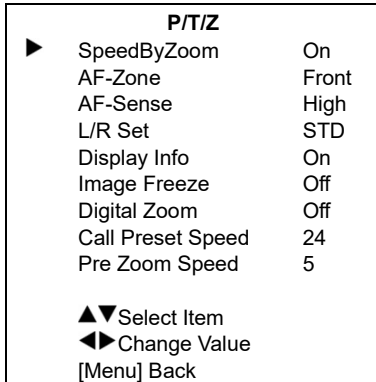

- SpeedByZoom: On, Off.
- AF-Zone: Front, Top, Center, Bottom.
- AF-Sense: Low, Normal, High.
- L/R Set: STD, REV.
- Display Info: On, Off.
- Image Freeze: On, Off.
- Digital Zoom: Off, 2x, 4x, 8x, 16x.
- Call Preset Speed: 1 ~ 24.
- Pre Zoom Speed: 0 ~ 7.

5.6 NOISE REDUCTION

Move the main menu cursor to [Noise Reduction], and press [HOME] key enter the noise reduction page, as shown in the following figure.

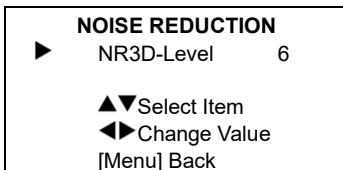

NR3D-Level: Off, 1 ~ 9.

5.7 SETUP

Move the main menu cursor to [Setup], and press [HOME] key enter the setup page, as shown in the following figure.

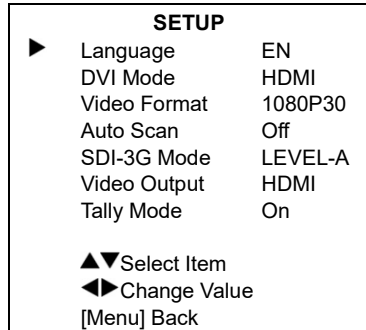

- Language: EN, Chinese, Russian.
- DVI Mode: DVI, HDMI.
- Video Format: 4KP25, 4KP29.97, 4KP30, 4KP50, 4KP59.94, 4KP60, 1080P30, 1080P25, 1080P50, 1080P60, 1080P59.94, 1080P29.97, 1080I50, 1080I60, 1080I59.94, 720P60, 720P59.94, 720P50.
- Auto Scan: On, Off.
- SDI-3G Mode: LEVEL-A, LEVEL-B
- Video Output: HDMI, SDI.
- Tally Mode: On, Off.

5.8 COMMUNICATION SETUP

Move the main menu cursor to [Communication Setup], and press [HOME] key enter the communication setup page, as shown in the following figure.

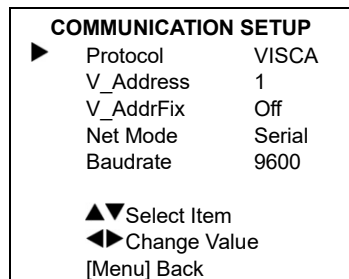

Protocol: Auto, VISCA, PELCO-D, PELCO-P.
 V_Address: 1 ~ 7 (Effective only in Auto, VISCA protocol).
 V_AddrFix: On, Off (When set to On, useless in 88 30 01 FF Command).
 P_D_Address: 0 ~ 254 (Effective only in Auto, PELCO-D protocol).
 P_P_Address: 0 ~ 31 (Effective only in Auto, PELCO-P protocol).
 Net Mode: Serial, Paral.
 Baudrate: 2400, 4800, 9600, 38400.

5.9 RESTORE DEFAULT

Move the main menu cursor to [Restore Default], press [HOME] key enter restore default page, as shown in the following figure.

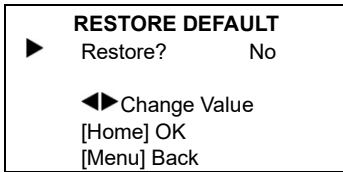

Restore: Yes, No.

Note GUI menu and parameters are subject to change without notice.

6 Network Function

6.1 Operating Environment

Operating System: Windows 7/8/10, Mac OS X, Linux, Android
 Network Protocol: TCP/IP
 Client PC: P4/128M RAM/40G HDD/ support scaled graphics card, support DirectX 8.0 or more advanced version.

6.2 Equipment Installation

- 1) Connect video conference camera to your internet or to your PC via network cable.
- 2) Turn on DC 12V power.

- 3) If the network connection is normal, the connection light (green) at the network interface will light up within 5 seconds, and the data indicator (orange) will flash, indicating that the physical connection of the camera has been completed.

6.3 Internet Connection

There are two main ways to connect video conference camera.



Connect by Network Cable

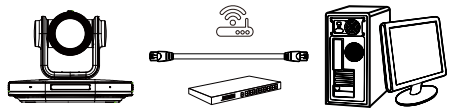

Connect by Switch/Router

6.4 Camera Controlled by LAN

6.4.1 Setup IP Address

If you don't know camera IP, view as below:
 Method 1: Press * and # and 4 on remote controller one by one, the camera IP address will be shown on screen.

Method 2: Connect camera to PC with network cable, use "upgrade_En.exe" to search for IP address.



upgrade

Change IP address, two methods as below:
 Method 1: Login the web page, select "Network > Lan Settings", change IP address, subnet mask and gateway. Click "Submit" and restart the camera.

Lan Settings

IP Configuration Type: Fixed IP Address

IP Address: 192.168.100.88

Subnet Mask: 255.255.255.0

Gateway: 192.168.100.1

DNS Address: 8.8.8.8

MAC Address: D4 E0 8E A3 AA A6

Submit Cancel

Port Settings

HTTP Port: 80

RTSP Port: 554

TCP Port: 5678

UDP Port: 1259

Sony Visca: 52381

RTMP (S) Settings

First Stream: On Off Video Audio

MRL: rtmp://192.168.100.138/live/stream0

Second Stream: On Off Video Audio

MRL: rtmp://192.168.100.138/live/stream1

SRT Settings

SRT: On Off

SRT Port: 4578

SRT Encryption: None

SRT Password: 1234564913131

RTSP Settings

RTSP Auth: On Off

ONVIF Settings

ONVIF: On Off

ONVIF Auth: On Off

Multicast Settings

Multicast: On Off

Address: 224.1.2.3

Port: 6688

NTP Settings

NTP time sync: On Off

Time Zone: (GMT+08:00) Beijing, Chn

Server address: cn.ntp.org.cn

Time interval(min): 1440

Main time show: On Off

Position: X 0 Y 0

Sub time show: On Off

Position: X 0 Y 0

Method 2: Open “upgrade_en.exe”, Select the “Config” dialog, change IP Address and click “Set”. After modified, the video conference camera will be restart.

Config Backup

Mode: Manual Snapshot

IP Address: 192.168.100.88

NetMask: 255.255.255.0

GateWay: 192.168.100.1

First DNS: 8.8.8.8

MAC Address: [D4] : [E0] : [8E] : [A0] : [41] : [F5]

Set Rewrite Default

Change IP address:

Step 1 Search the IP address of camera.

Step 2 Select the camera IP of you want to change.

Step 3 Select the config dialog of upgrade applets.

Step 4 Change the IP address, netmask and gateway, then click “Set”.

Step 5 Finish.

6.4.2 Visit/Access Camera

Input http://192.168.100.88 to web browser, the login window pop up, input username: admin, password: admin, shown as below:



After login, shown as below:



Tips

IE browser does not support H5, you need to use VLC plug-in to view videos. Please visit VLC website (<http://www.videolan.org/vlc>) download and install the 32-bit VLC media player, after it installed, visit video conference camera will have normal image display. Other mainstream browsers already support H5 and do not need to install the VLC plug-in.

6.5 Camera Controlled by WAN

6.5.1 Setup IP Controlled by Dynamic DNS

Two dynamic DNS: DynDNS.org, 3322.org.

Router Port Mapping:

Take Tenda router for example, enter the Router Home Page (interface page), select “Advanced”- “Virtual Server”, add a new port number in “Ext Port”, add a new port number in “Int port”, put camera IP address to “Internal IP”, then select “Save”, shown as below:

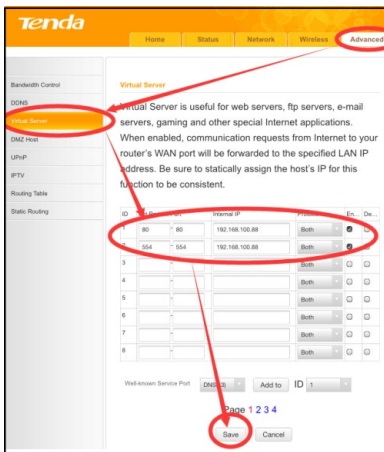

6.5.2 Dynamic DNS Visit Camera

Set domain name to camera, setup the parameter, then dynamic DNS can access camera. Access link: `http://hostname: port number`. For example, setup host computer name: `youdomain.f3322.org`, the camera port number is 89, the access link should be <http://youdomain.3322.org:89>.



Tips

If the camera port default is 80, then unnecessary to input port number, use host name can access camera directly.

6.5.3 VLC Stream Media Player Monitor

Visit VLC Media Server Procedure

Step 1 Open VLC media player.

Step 2 Click “Media > Open Network Stream”, or click “Ctrl + N”; as below:

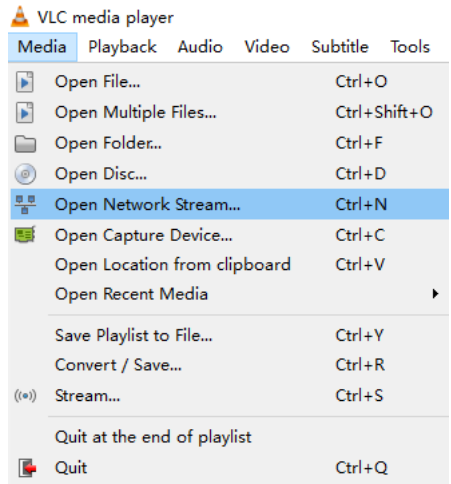

Step 3 Input URL address:

`rtsp://ip: port number/1` (First stream);

`rtsp://ip: port number/2` (Second stream).

Step 4 Click “Play”.



RTSP port number default 554. If the camera port default is 80, then unnecessary to input port number of URL address.

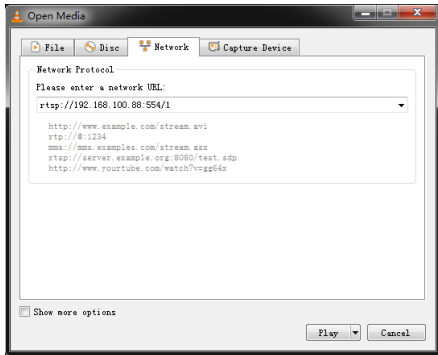

6.6 Camera Parameter Setup

6.6.1 Homepage Introduction

Menu

All pages include two menu bars:

Real time monitoring: displaying video image

Parameter setup: with function buttons.

A. Video Viewing Window

Video viewing window must be same as video resolution, the bigger the resolution is, the bigger the playing area is. Double click viewing window, will show full-screen, double click again, will return to initialized size.

Status bar in viewing window shown as below:



- 1) Video playback pause button: control real-time video pause, stop the last picture, click recoverable video again.
- 2) Audio control buttons: can adjust the volume or set silent mode.
- 3) Full screen switch button.

B. PTZ Setup

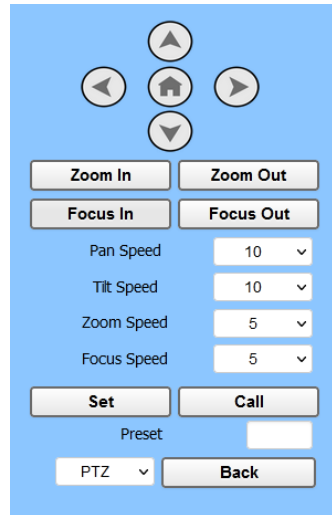

1) Pan and Tilt Control

Up, Down, Left and Right arrows and the home button allow you to manually drive the camera to the desired position.

2) Zoom

Zoom In and Zoom Out buttons allow for wide or narrow view of the space.

3) Focus

Focus In and Focus Out buttons allow for fine manual focus adjustment if the camera has any problems auto focusing on the difficult object.

4) PTZ Speeds

Pan speed can be set at any rate between 1 ~ 24, Tilt speed can be set at any rate between 1 ~ 20. Zoom and Focus speeds can be set at any rate between 0 ~ 7.

1) PTZ Presets

After manually setting up a shot that you would like to return to later, you can save presets for quick recall of these positions. Type a number between 0 and 254 into the Preset box.

Click the "Set" button to save the current location with that preset number. Click the "Call" button to cause the camera to return to that position. This enables smooth, quick and convenient control without the need to manually drive the camera.

You can set up preset that user want as below. Method: Type a number into the preset box.

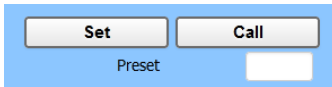

Preset: Optional items: 0 ~ 254.

5) PTZ / OSD Dropdown

From the dropdown menu, clicking the OSD option will open the on-screen display menu of the camera giving you control from within the IP interface.

C. Language Selection

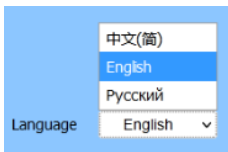

Click either "Chinese", "English" or "Russian" to change the language of the webpage.

6.6.2 Video Settings

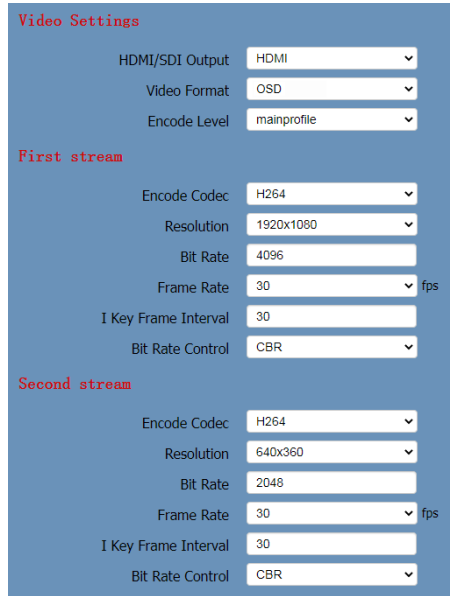

1) HDMI/SDI Output

Support HDMI and SDI output methods.

2) Video Format

Support 50Hz (PAL), 60Hz (NTSC) and OSD three formats.

3) Encode Level

Support mainprofile and highprofile two levels.

4) Encode Protocol

Support H.264, H.265 and MJPEG three protocols.

5) Resolution

First stream support 3840x2160, 1920x1080, 1280x720, 1024x576, 720x480, 720x408, 640x480, 640x360. Second stream support 720x480, 720x408, 640x480, 640x360, 480x320, 320x240; The bigger resolution is, the clearer the image will be, more network bandwidth will be taken.

6) Bit Rate

The user can specify the bit rate. Generally speaking, the larger of the bit rate, the clearer of the image. However, the configuration of the bit rate needs to be combined with the network bandwidth. When the network bandwidth is narrow and the bit rate is configured larger, the video stream cannot be transmitted normally, and the visual effect is worse.

7) Frame Rate

User can specify the size of the frame rate, generally, the frame rate greater, the image more smooth; Frame rate is smaller, the more sense of beating.

8) I Key Frame Interval

Set interval between 2 I frame, the bigger interval is the response will be lower from viewing window.

9) Bit Rate Control

CBR (Constant Bit Rate): Video coder will be coding according to preset speed.

VBR (Variable Bit Rate): Video coder will adjust the speed based on preset speed to gain the best image quality.

6.6.3 Image Settings



Brightness - 7 +

Saturation - 4 +

Contrast - 7 +

Sharpness - 6 +

Hue - 7 +

Flip on off

Mirror on off

1) Brightness

Brightness 0 ~ 14, default value is 7.

2) Saturation

Saturation 0 ~ 14, default value is 4.

3) Contrast

Contrast 0 ~ 14, default value is 7.

4) Sharpness

Sharpness 0 ~ 11, default value is 6.

5) Hue

Hue 0 ~ 14, default value is 7.

6) Flip & Mirror

Tick Flip to realize image upside down, tick mirror to realize image around the mirror. Default value is not tick.

6.6.4 Audio Settings

Audio Settings

Audio Switch On

Audio Type AAC

Sample Rate 48K

Bit Rate 96K

Input Type LINE IN

Input Vol 20 dB

ADTS Options Off

1) Audio Switch

Turn on or off audio switch.

2) Audio Type

Audio type AAC, G711A.

3) Sample Rate

Optional items: 44.1K, 48K.

4) Bit Rate

Optional items: 96K, 128K.

5) Input Type

Optional items: LINE IN.

6) Input Vol

The volume of the channel input.

7) ADTS Options

Optional items: On, Off.

6.6.5 System Settings

Initialize

Reboot

User

UserName

Passwd

Guest

Passwd

1) Reboot

Click the “Reboot” button, system restart.

2) Username and Password

The user can modify the password (letters and Numbers only).

6.6.6 Network Settings

Lan Settings

IP Configuration Type

IP Address

Subnet Mask

Gateway

DNS Address

MAC Address

Port Settings

HTTP Port

RTSP Port

TCP Port

UDP Port

Sony Visca

RTMP(S) Settings

First Stream On Off Video Audio

MRL

Second Stream On Off Video Audio

MRL

SRT Settings

SRT On Off

SRT Port

SRT Encryption

SRT Password

RTSP Settings

RTSP Auth On Off

ONVIF Settings

ONVIF On Off

ONVIF Auth On Off

Multicast Settings

Multicast On Off

Address

Port

NTP Settings

NTP time sync On Off

Time Zone

Server address

Time interval(min)

Main time show On Off

Position

Sub time show On Off

Position

1) Lan Settings

Default the IP address is 192.168.100.88, the MAC address cannot be modified.

2) Port Settings

A. HTTP Port

IP address identifies the network device, the device can run multiple web applications, each network program using network port to transmit data, so data transmission to be carried out between the port and port. Port setting is to set up web server program using which port to transmit. When port mapping, need to be consistent with the port number (default port: 80).

B. RTSP Port

The video conference camera support RTSP protocol, use the VLC tools broadcast, default port: 554.

C. TCP Port

Support TCP connection then control camera, default port: 5678.

D. UDP Port

Support UDP protocol, default port: 1259.

E. Sony Visca

Support Sony Visca, default value: 52381.

3) RTMP(S) Settings

Setting the MRL of RTMP, select enable or disable video and audio. You can select control code stream of “On”, “Off”, “Video”, “Audio” between in the two streams.

4) SRT Settings

Turn On/Off SRT, Setting the SRT Port, SRT Encry and SRT Password.

5) RTSP Settings

Turn On/Off RTSP Auth.

6) ONVIF Settings

Turn On/Off ONVIF and ONVIF Auth.

7) Multicast Settings

Turn On/Off multicast. Setting the multicast address (default value is 224.1.2.3) and port (default value is 6688, then 6688 is the multicast port of the first stream; 6690 is the multicast port of the second stream).

8) NTP Settings

Turn On/Off NTP time sync, main time show and sub time show. Setting NTP server address, time interval, main stream position and sub stream position.

6.6.7 NDI® Config

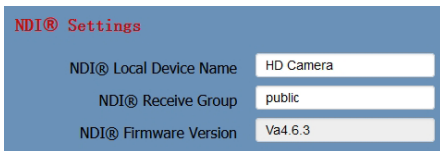

NDI® Settings	
NDI® Local Device Name	HD Camera
NDI® Receive Group	public
NDI® Firmware Version	Va4.6.3

1) NDI® Local Device Name

Setting the NDI® Local Device Name.

2) NDI® Receive Group

Setting the NDI® Receive Group.

3) NDI® Firmware Version

View NDI® Firmware Version.

6.6.8 Device Information

Display the current device information.

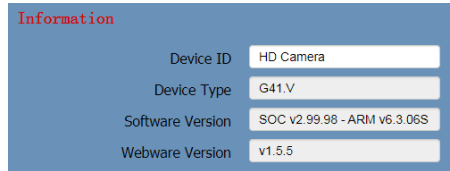

Information	
Device ID	HD Camera
Device Type	G41.V
Software Version	SOC v2.99.96 - ARM v6.3.06S
Webware Version	v1.5.5

6.7 Download the Upgrade Program

If you need the camera upgrade program, please contact the manufacturer.



Note WEB interface and parameters are subject to change without notice.

7 Maintenance and Troubleshooting

Camera Maintains

- If camera will not be used for a long time, please turn off power switch, disconnect AC power cord of AC adaptor to the outlet.
- Please use soft cloth or tissue to clean the camera cover.
- Please use the soft dry cloth to clean the lens. If the camera is very dirty, clean it with diluted neuter detergent. Do not use any type of solvents, which may be damage the surface.

Unqualified Application

- No shooting extreme bright object for a long period of time, such as sunlight, light sources, etc.
- No operating in unstable lighting conditions, otherwise image will be flickering.

- No operating close to powerful electromagnetic radiation, such as TV or radio transmitters, etc.

Troubleshooting

Image

- The monitor shows no image

- 1) Check that the camera power supply is connected, the voltage is normal, and the power indicator light is always on.
- 2) Turn off the power switch to check whether the camera is self-testing.
- 3) Check the cable of video platform and TV whether correct connection.

- Sometimes without the image

Check the cable of video platform and TV whether correct connection.

- Image have jitter when the camera lens at max multiple

- 1) Check whether the camera installed position be stabled.
- 2) Check whether have vibrating machinery or object near the camera.

- There is no video image in Browser

IE browser does not support H5, you need to use VLC plug-in to view videos. Please visit VLC website (<http://www.videolan.org/vlc>) download and install the 32-bit VLC media player, after it installed, visit video conference camera will have normal image display. Other mainstream browsers already support H5 and do not need to install the VLC plug-in.

- Unable to access video conference camera through Browser

- 1) Using PC to access the network to test whether the network access can work properly, first of all, the network fault caused by the PC virus can be eliminated, until the PC and video conference camera can communicate with each other Ping.
- 2) Disconnect the network, connect video

conference camera and PC separately, and reset the IP address of PC.

- 3) Check IP address, subnet mask, and gateway settings for video conference camera.
 - 4) Check whether the MAC address is conflicts.
 - 5) Check whether the web port is modified. The default is 80.
- Forget the IP address or login password

Please remember (The default IP address: 192.168.100.88; default user name: admin; default password: admin).

Control

- Remote control cannot control
 - 1) Check and replace the new battery for the remote controller.
 - 2) Check whether the camera working mode is correct.
 - 3) Check whether the address of remote control can match the camera.
- Serial port cannot control
 - 1) Check whether the camera protocol, address and baud rate such is the same.
 - 2) Check whether the control line is connected well.